

Bullard AirGladiator Filters can be used in conjunction with other compressor safeguards to supply cleaner air to airline respirators. They can also be used to supply drier, cleaner air to pneumatic tools and systems. AirGladiator provides 7-stage filtration to the required Grade D breathable air that when combined with carbon monoxide (CO) monitoring and other safeguards provides workers with cleaner, more comfortable air. AirGladiator has been independently verified through third-party testing to be highly effective at filtering 0.5 micron particle size and greater.

Bullard airline filters will NOT remove carbon monoxide and other toxic gases from the airline. AirGladiator does NOT create Grade D breathable air.

Set-Up

1. Location:

Select a flat, stable location to mount the filter. Bolt the filter in position using the mounting base. For wall mount applications, the filter carrying handle is designed for mounting the unit to a wall.

▲ WARNING

AirGladiator and any air compressor MUST be located in a safe, clean air environment containing at least Grade D breathable air to prevent entry of contaminated air into the air supply system. A minimum of Grade-D breathable air must be supplied to AirGladiator at all times.

Failure to read, understand and follow all instructions and warnings could lead to death or serious injury or delayed lung disease including but not limited to silicosis, pneumoconiosis or asbestosis.

2. Connection:

Connect compressor hose to the air inlet. Connect the respirator or pneumatic tool airline hose to the filter outlet. Tighten the connections to prevent leaks and possible pressure loss.

3. Assembly

Install the regulator inlet assembly by screwing the 1" male nipple on the end of the assembly into the 1" female inlet port on the filter body. Use Teflon® tape or thread sealant on the male threads before installing. Tighten with a wrench.

⚠ NOTE:

Check to make sure the direction arrow, engraved on the Pressure Regulator, is pointing toward the 1" female inlet port - this arrow indicates the proper direction of "AIRFLOW" to allow the Pressure Regulator to work as designed.

▲ WARNING

Always use NIOSH approved supplied air respirators that are suitable for the operations being conducted. When using the respirator, do not connect the AirGladiator filter to any air source unless you are certain it supplies at least Grade D breathable air. Failure to provide at least Grade D breathable air could result in death or serious injury or life-threatening delayed lung disease including but not limited to silicosis, pneumoconiosis, or asbestosis.

▲ WARNING

The AirGladiator filters do not remove carbon monoxide and other toxic gases. Review and observe all pertinent federal and state safety regulations in conjunction with airline respirators. Failure to observe safety regulations or improper use of AirGladiator could result in death or serious injury or life-threatening delayed lung disease including but not limited to silicosis, pneumoconiosis, or asbestosis.

1. Air Requirements

a. Air Source Monitoring:

Federal Law requires use of carbon monoxide and/or high temperature monitors or alarms when oil lubricated compressors are used as sources of breathing air. If only a high temperature alarm is used, you must frequently test the compressor air for carbon monoxide to ensure it meets the Grade D requirements discussed below.

The law also requires that breathing air hose couplings be incompatible with outlets for other gas systems in order to prevent accidental connection of a supplied air respirator to non-respirable gases.

b. Quality of Breathing Air:

Supplied breathing air entering and passing through this filter to a respirator must meet at least the requirements for Grade D air as described in the Compressed Gas Association Commodity Specification G7.1, and as specified by federal law 42 CFR, Part 84, Subpart J, 84.141(b) and 29 CFR 1910.134(i). The Bullard airline filter does not remove carbon monoxide and other toxic gases from the air being supplied. The requirements for Grade D breathable air include:

- | | |
|--|--------------------------|
| • Oxygen | 19.5 - 23.5% |
| • Hydrocarbons (condensed) | 5 mg/m ³ max. |
| • Carbon Monoxide | 10 ppm max. |
| • Carbon Dioxide | 1000 ppm max. |
| • Odor | Lack of noticeable odor |
| • No toxic contaminants at levels which would make the air unsafe to breathe. (See 29 CFR 1910.1000) | |

Refer to the C.G.A. Commodity Specifications G7.1 for complete details. It is available from: Compressed Gas Association, (WWW.CGANET.COM).

c. Air Pressure:

The air pressure at the filter inlet is a recommended maximum pressure of 100 psig (6.9 bar). Air will be released by the pressure relief valve when pressure within the filter exceeds 125 psig (8.6 bar). Air discharging from the filter can be controlled to meet specific air pressure requirements by using the pressure regulator adjustment knob. Refer to your respirator or pneumatic tool instruction manual to find the appropriate air pressures required for correct use of the equipment.

d. Temperature:

Air supplied to the filter should not exceed 140° F (60° C). Therefore, do not connect the filter directly to the compressor exhaust manifold.

2. Correct Operation Procedures

a. **Drain** accumulated water and oil from the filter tank as required by opening the petcock drain valve. Normally the tank will need to be drained at least once a day. In humid climates, or if large amounts of water and oil are present in the air supply, drain the filter tank more often.

b. **Tighten** the fasteners which secure the head to the filter tank. Over time, the fasteners may loosen which could cause a leak in the air system. (Recommended torque is 20 lbf-ft).

Cartridge Replacement

⚠ WARNING

Use only Bullard 41AF cartridges as replacements. Bullard AirGladiator Filters are designed to use only Bullard filter cartridges. Failure to use the correct filter cartridge could result in death or serious injury or life-threatening delayed lung disease including but not limited to silicosis, pneumoconiosis, or asbestosis.

The frequency of filter cartridge replacement depends on the conditions of the particular air system in which the filter is installed. Under normal operating conditions which includes a continuous supply of Grade D breathable air to the filter, at a minimum, the 41AF filter cartridge should be changed annually. However, the filter cartridge should be replaced immediately if:

- The user smells or tastes contaminants in the air being supplied to an air-supplied respirator, or;
- There is a large pressure drop across the AirGladiator Filter, even though the compressor and other components appear to be operating correctly.
- The filter has been in use for approximately one (1) year.

Corrective Action

- Shut off air supply and drain filter. Disconnect the filter from the air source before servicing.
- Replace the Cartridge:
 - Separate the filter head from the cylinder housing by removing the bolts, nuts, and lock washers from the top flanges.
 - After removing the 41AF filter cartridge, clean the inside of the tank to remove any remaining contaminants.
 - Insert a new Bullard 41AF filter cartridge. Tighten all the fasteners in a crossing (star) bolt pattern (not in a circular pattern) to ensure maximum tightness is evenly achieved. See Figure 3. This will help prevent warping of the filter head (Recommended tightness = 20 lbf-ft).
- Record the date the filter was replaced on the label attached to the airline filter tank. You can develop a filter cartridge replacement schedule by monitoring the frequency with which the cartridge needs to be changed.

4. Reconnect the filter to the Grade D air source before use.

5. If conditions are not improved, do not use the filter until appropriate corrective measures have been taken including but not limited to analyzing the source of the supplied air.

Replaceable Filter Cartridge (7-Stage Operation)

Cartridges effectively trap and remove impurities with little pressure loss. The supplied-air enters the filter at the inlet connector, travels through 6 layers of filter material, and exits at the outlet connector. Filter materials work in sequence to trap and hold water, oil, particulates, odors, and organic vapors so that cleaner air is delivered to workers or equipment.

⚠ WARNING

Filter cartridge must be changed periodically for maximum efficiency. Frequency of cartridge changes depends on operating conditions. At a minimum, Bullard recommends changing the 41AF filter cartridge at least every six months. Cartridge should be changed immediately if respirator wearer feels, smells or tastes contaminants inside the respirator. Filter tank should be drained at least daily to remove trapped water and oil (a petcock is provided on the bottom of the tank for this purpose). Failure to read, understand and follow all instructions and warnings could result in death or serious injury or life-threatening delayed lung disease including but not limited to silicosis, pneumoconiosis, or asbestosis.

Follow Bolt Tightening Star Pattern using only Hand-Tightened Bolts. Follow Star Pattern again to 50% Full Torque Load. Follow Star Pattern again to 100% Full Torque Load.

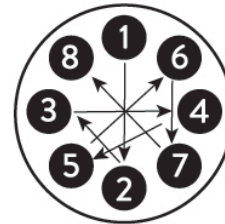

8 Lug Tightening Pattern

Figure 3 - Recommended 8 Bolt Tightening Pattern (STAR)

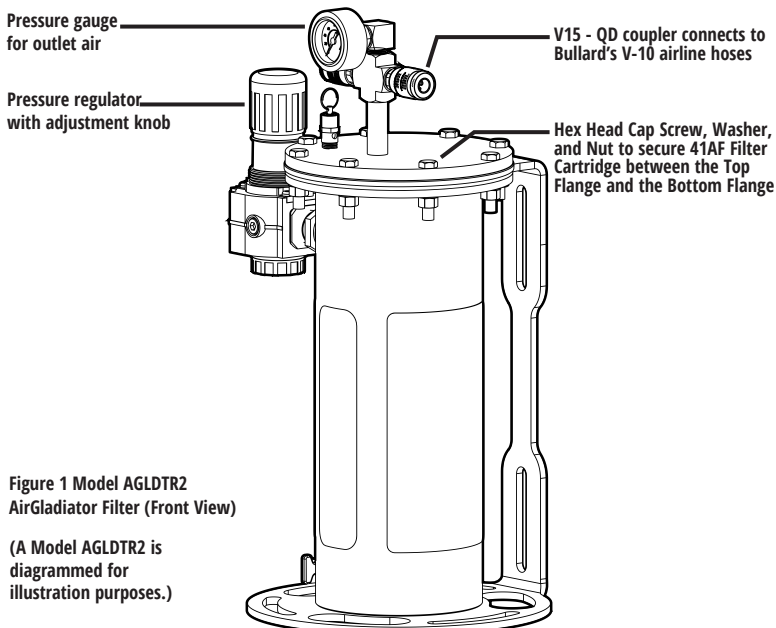

Figure 1 Model AGLDTR2 AirGladiator Filter (Front View)

(A Model AGLDTR2 is diagrammed for illustration purposes.)

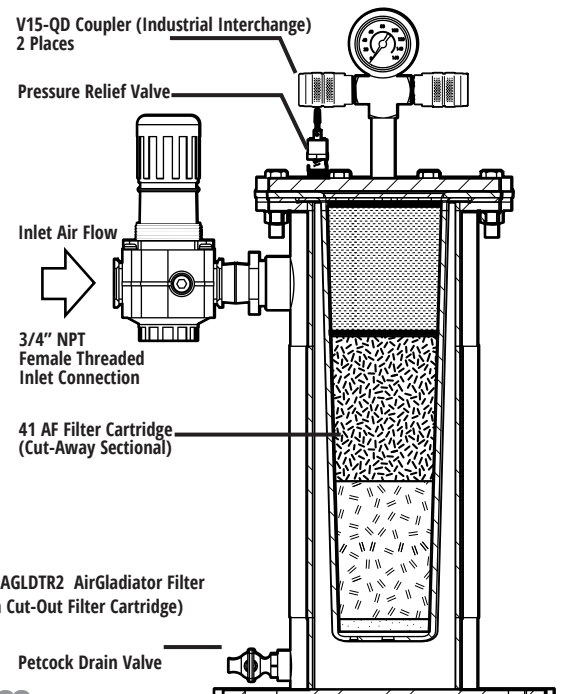

Figure 2 Model AGLDTR2 AirGladiator Filter (Side View with Cut-Out Filter Cartridge)

AirGladiator Airline Filters User Manual

One Year LIMITED Warranty

Bullard warrants to the original purchaser that the AirGladiator will be free of defects in material and workmanship under normal use and service for a period of one (1) year from the date of purchase. Bullard's obligation under this warranty is limited to repairing or replacing, at its option, parts that are returned within the warranty period and that are, after examination, shown to Bullard's satisfaction to be defective, subject to the following limitations.

- a) AirGladiator must be returned to the Bullard factory with shipping charges prepaid.
- b) AirGladiator must not be altered from its original factory configuration.
- c) AirGladiator must not have been misused, subjected to negligent use, or damaged in transport.
- d) The date of purchase is within the one year warranty period. (A copy of the purchaser's original invoice showing the date of purchase is required to validate warranty coverage.)

In no event shall Bullard be responsible for damages for loss of use or other indirect, incidental, consequential or special costs, expenses or damages incurred by the purchaser, notwithstanding that Bullard has been advised of the possibility of such damages.

ANY IMPLIED WARRANTIES, INCLUDING WARRANTIES OF MERCHANTABILITY AND FITNESS FOR A PARTICULAR PURPOSE, ARE SPECIFICALLY EXCLUDED FROM THIS WARRANTY.

Some states do not allow the exclusion or limitation of incidental or consequential damages, or allow limitations on how long an implied warranty lasts, so the above limitations or exclusion may not apply to you. This warranty gives you specific legal rights, and you may have other rights which vary from state to state.

Return Authorization

The following steps must be completed before Bullard will accept any returned goods. Please read carefully.

Follow the steps outlined below to return goods to Bullard for repair or replacement under warranty or for paid repairs:

1. Contact Bullard Customer Service by telephone or in writing at: E.D. Bullard Company 1898 Safety Way Cynthiana, KY 41031-9303 Toll-Free: 877-BULLARD (285-5273) Phone: 859-234-6616 In your correspondence or conversation with Customer Service, describe the problem as completely as possible. For your convenience, the representative will try to help you correct the problem over the phone.
2. Verify with your representative that the product should be returned to Bullard. Customer Service will provide you with written permission and a return authorization number.
3. Before returning the product, decontaminate and clean it to remove any hazardous materials which may have settled on the product during use. Laws and/or regulations prohibit the shipment of hazardous or contaminated materials. Products suspected to be contaminated will be professionally discarded at the customer's expense.
4. Ship returned products, including those under warranty, with all transportation charges pre-paid. Bullard cannot accept returned goods on a freight collect basis.
5. Returned products will be inspected upon return to the Bullard facility. Bullard Customer Service will telephone you with a quote for required repair work which is not covered by warranty. If the cost of repairs exceeds stated quote by more than 20%, your representative will call you for authorization to complete repairs..

California Proposition 65 WARNING

Cancer and Reproductive Harm - www.P65Warnings.ca.gov.

Specifications

Airline Filter	AGLDTR2	AGLDTR2E	AGLDTR6
Max. Air Flow Rate	75 cfm (2120 Lpm)	75 cfm (2120 Lpm)	75 cfm (2120 Lpm)
Inlet Connection	1" NPT (Fem.)	19mm (3/4") BSPT (Fem.)	1" NPT (Fem.)
Outlet Connection	2 outlets 3/8" NPT (Fem.)	2 outlets 3/8" NPT (Fem.)	6 outlets 3/8" NPT (Fem.)
Relief Valve	125 psig (8.6 bar)	125 psig (8.6 bar)	125 psig (8.6 bar)
Tank Diameter	5 1/2" (14 cm)	5 1/2" (14 cm)	5 1/2" (14 cm)
Height	22" (55.9 cm)	22" (55.9 cm)	18.5" (47 cm)
Weight	29 lb (13.2 kg)	29 lb (13.2 kg)	32 lb (14.5 kg)

AirGladiator Ordering Information

Part Number	Description
Airline Filter	
AGLDTR2	2-outlet filter with pressure gauge, relief valve, pressure regulator, and hose adapter fittings (2 hose adapter fittings)
AGLDTR2E	2-outlet filter with pressure gauge, relief valve, pressure regulator, and hose adapter fittings (2 hose adapter fittings)
AGLDTR6	6-outlet filter with pressure gauge, relief valve, pressure regulator, and hose adapter fittings (6 hose adapter fittings)

*Replacement Parts and Accessory Items

Part Number	Description
41AF	Replacement Filter Cartridge
AGLDAFCL5PK	iChange of Filter Cartridge Labels (5 pack)
AGLDDRAIN	Petcock Drain Valve
AGLDTR6R	Pressure Regulator (No Gauge)
AGLDPRV	Pressure Relief Valve (125 psig / 8.6 bar)
AGLDRG	Pressure Gauge
AG10FTCABKIT	AirGladiator to CAB Connection Kit

*Full List Available on Bullard.com

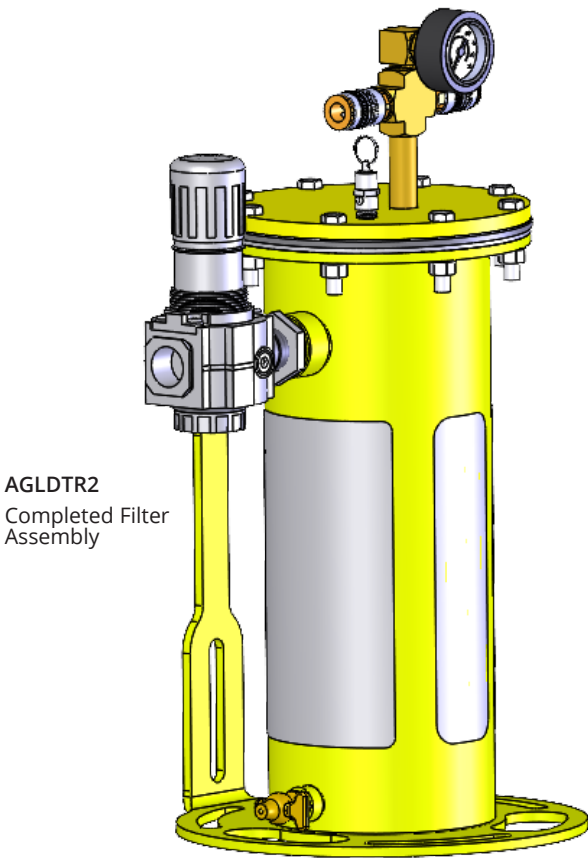

Three (3) Sub-Assembly Parts

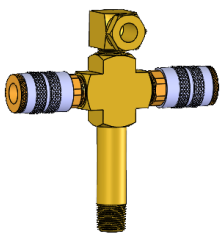

Outlet Air Piping Assembly

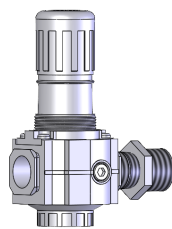

Inlet Air - Pressure Regulator

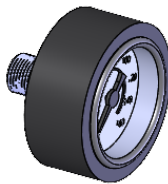

Pressure Gauge

NOTE:

When reinstalling or replacing the 41AF Filter Cartridge, tighten by hand in a crossing (star) bolt pattern. Then, secure the bolts by torquing each bolt to a minimum of 20 lbf-ft using the same crossing (star) pattern. See below Lug Tightening Pattern for reference.

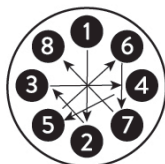

8 Lug Tightening
Pattern

WARNING

Always use NIOSH approved supplied air respirators that are suitable for the operations being conducted. When using the respirator, do not connect the AirGladiator filter to any air source unless you are certain it supplies at least Grade D breathable air. Failure to provide at least Grade D breathable air could result in death or serious injury or life-threatening delayed lung disease including but not limited to silicosis, pneumoconiosis, or asbestosis.

WARNING

The AirGladiator filters do not remove carbon monoxide and other toxic gases. Review and observe all pertinent federal and state safety regulations in conjunction with airline respirators. Failure to observe safety regulations or improper use of AirGladiator could result in death or serious injury or life-threatening delayed lung disease including but not limited to silicosis, pneumoconiosis, or asbestosis.

Set-Up of AirGladiator Filter:

1. Location:

Select a flat, stable location to mount the filter. Bolt the filter in position using the mounting base. For wall mount applications, the filter carrying handle is designed for mounting the filter to a wall or steel beam.

2. Assembly

Three (3) separate sub-assembly parts have been shipped with the filter. Each sub-assembly needs to be installed onto the filter in order to complete the AirGladiator Filter Assembly before it is connected to the Compressed Air Supply Piping.

- Dupont™ Teflon® tape or thread sealant can be used to ensure tight-fitting connections (No Air Leakage) before installation of all these sub-assembly parts.
- Inlet Air - Pressure Regulator has an 1" NPT Male Connector which must be threaded into the AirGladiator Filter's 1" NPT Female Connector.

NOTE:

Check to make sure the direction arrow, engraved on the Pressure Regulator, is pointing toward the 1" female inlet port - this arrow indicates the proper direction of "AIRFLOW" to allow the Pressure Regulator to work as designed.

- Outlet Air - Piping Assembly has a 3/8" NPT Male connector which must be threaded into the AirGladiator Filter's 3/8" NPT Female Connector on Top of the Filter Flange.
- Pressure Gauge for Outlet Air has an 1/4" NPT Male Back Connector which must be threaded into the 1/4" NPT Female Connector in the Top Bushing of the Outlet Air Piping.

3. Connections

Connect compressor hose or piping to Inlet Air - Pressure Regulator (3/4" NPT Female). Connect the respirator system or pneumatic tool airline hose to the Quick Disconnect Coupling on the Outlet Air Piping. Tighten all piping connections to prevent air leaks and/or air pressure loss.

California Proposition 65 WARNING

Cancer and Reproductive Harm - www.P65Warnings.ca.gov.

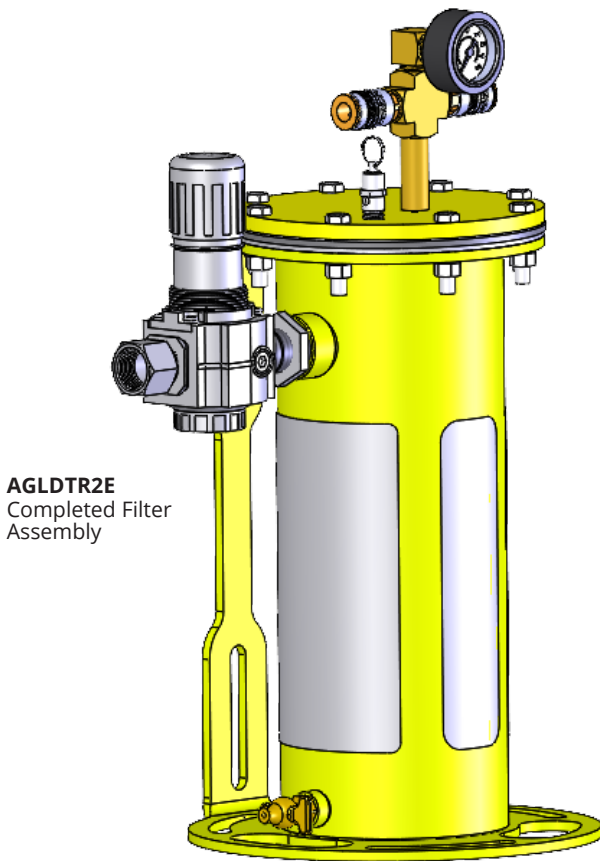

AGLDTR2E
Completed Filter
Assembly

Three (3) Sub-Assembly Parts

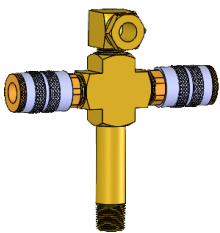

Outlet Air Piping Assembly

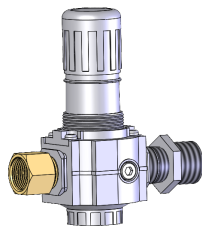

Inlet Air - Pressure Regulator
with the EN Adapter installed

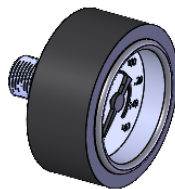

Pressure Gauge

NOTE:

When reinstalling or replacing the 41AF Filter Cartridge, tighten by hand in a crossing (star) bolt pattern. Then, secure the bolts by torquing each bolt to a minimum of 20 lbf-ft using the same crossing (star) pattern. See below Lug Tightening Pattern for reference.

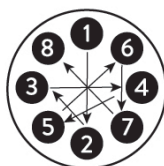

8 Lug Tightening
Pattern

WARNING

Always use NIOSH approved supplied air respirators that are suitable for the operations being conducted. When using the respirator, do not connect the AirGladiator filter to any air source unless you are certain it supplies at least Grade D breathable air. Failure to provide at least Grade D breathable air could result in death or serious injury or life-threatening delayed lung disease including but not limited to silicosis, pneumoconiosis, or asbestosis.

WARNING

The AirGladiator filters do not remove carbon monoxide and other toxic gases. Review and observe all pertinent federal and state safety regulations in conjunction with airline respirators. Failure to observe safety regulations or improper use of AirGladiator could result in death or serious injury or life-threatening delayed lung disease including but not limited to silicosis, pneumoconiosis, or asbestosis.

Set-Up of AirGladiator Filter:

1. Location:

Select a flat, stable location to mount the filter. Bolt the filter in position using the mounting base. For wall mount applications, the filter carrying handle is designed for mounting the filter to a wall or steel beam.

2. Assembly

Three (3) separate sub-assembly parts have been shipped with the filter. Each sub-assembly needs to be installed onto the filter in order to complete the AirGladiator Filter Assembly before it is connected to the Compressed Air Supply Piping.

- Dupont™ Teflon® tape or thread sealant can be used to ensure tight-fitting connections (No Air Leakage) before installation of all these sub-assembly parts.
- Inlet Air - Pressure Regulator has an 1" NPT Male Connector which must be threaded into the AirGladiator Filter's 1" NPT Female Connector.

NOTE:

Check to make sure the direction arrow, engraved on the Pressure Regulator, is pointing toward the 1" female inlet port - this arrow indicates the proper direction of "AIRFLOW" to allow the Pressure Regulator to work as designed.

- Outlet Air - Piping Assembly has a 3/8" NPT Male connector which must be threaded into the AirGladiator Filter's 3/8" NPT Female Connector on Top of the Filter Flange.
- Pressure Gauge for Outlet Air has an 1/4" NPT Male Back Connector which must be threaded into the 1/4" NPT Female Connector in the Top Bushing of the Outlet Air Piping.

3. Connections

Connect compressor hose or piping to Inlet Air - Pressure Regulator (3/4" BSPT Female). Connect the respirator system or pneumatic tool airline hose to the Quick Disconnect Coupling on the Outlet Air Piping. Tighten all piping connections to prevent air leaks and/or air pressure loss.

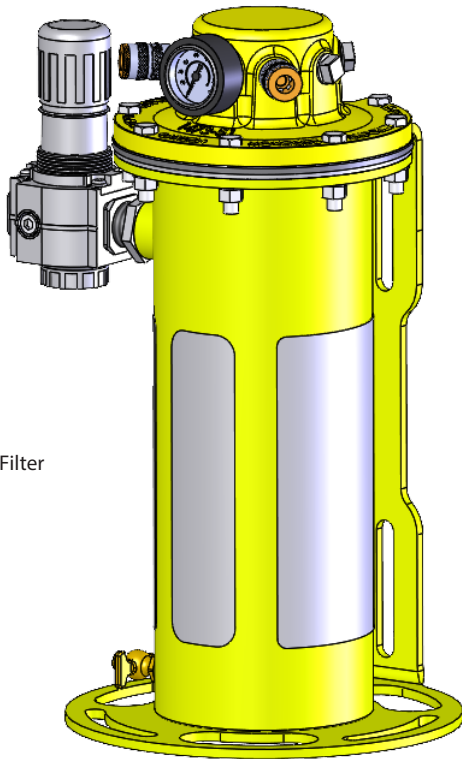

AGLDTR6
Completed Filter
Assembly

Three (3) Sub-Assembly Parts

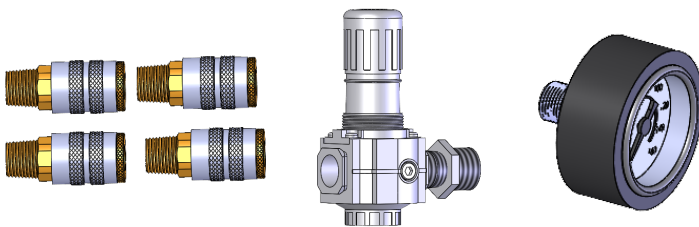

Additional Quick
Disconnect Couplings

Inlet Air - Pressure Regulator Pressure Gauge

NOTE:

When reinstalling or replacing the 41AF Filter Cartridge, tighten by hand in a crossing (star) bolt pattern. Then, secure the bolts by torquing each bolt to a minimum of 20 lbf-ft using the same crossing (star) pattern. See below Lug Tightening Pattern for reference.

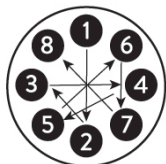

8 Lug Tightening
Pattern

Bullard Center
2421 Fortune Drive
Lexington, KY 40509 • USA
877-BULLARD (285-5273)
Tel: +1-859-234-6616
Fax: +1-859-246-0243

Americas Operations
1898 Safety Way
Cynthiana, KY 41031 • USA
877-BULLARD (285-5273)
Tel: +1-859-234-6616
Fax: +1-859-234-8987

Bullard GmbH
Dieselstrasse 8a
53424 Remagen • Germany
Tel: +49-2642 999980
Fax: +49-2642 9999829

Bullard Asia Pacific Pte. Ltd.
51 Changi Business Park
Central 2
#03-04 The Signature
Singapore 486066
Tel: +65 6745 0556

WARNING

Always use NIOSH approved supplied air respirators that are suitable for the operations being conducted. When using the respirator, do not connect the AirGladiator filter to any air source unless you are certain it supplies at least Grade D breathable air. Failure to provide at least Grade D breathable air could result in death or serious injury or life-threatening delayed lung disease including but not limited to silicosis, pneumoconiosis, or asbestosis.

WARNING

The AirGladiator filters do not remove carbon monoxide and other toxic gases. Review and observe all pertinent federal and state safety regulations in conjunction with airline respirators. Failure to observe safety regulations or improper use of AirGladiator could result in death or serious injury.

Set-Up of AirGladiator Filter:

1. Location:

Select a flat, stable location to mount the filter. Bolt the filter in position using the mounting base. For wall mount applications, the filter carrying handle is designed for mounting the filter to a wall or steel beam.

2. Assembly

Two (2) separate sub-assembly parts have been shipped with the filter. Each sub-assembly needs to be installed onto the filter in order to complete the AirGladiator Filter Assembly before it is connected to the Compressed Air Supply Piping.

- Dupont™ Teflon® tape or thread sealant can be used to ensure tight-fitting connections (No Air Leakage) before installation of all these sub-assembly parts.)
- Inlet Air - Pressure Regulator has an 1" NPT Male Connector which must be threaded into the AirGladiator Filter's 1" NPT Female Connector.

NOTE:

Check to make sure the direction arrow, engraved on the Pressure Regulator, is pointing toward the 1" female inlet port - this arrow indicates the proper direction of "AIRFLOW" to allow the Pressure Regulator to work as designed.

- Pressure Gauge for Outlet Air has an 1/4" NPT Male Back Connector which must be threaded into the 1/4" NPT Female Connector on the Top Flange of the Filter Outlet Air Connection Area.
- Additional Quick Disconnect Couplings have been shipped with this AirGladiator Filter. These extra Couplings allow the user to install a maximum of Six (6) Quick Disconnect Couplings around the Top Flange of the Filter.

3. Connection

Connect compressor hose or piping to Inlet Air - Pressure Regulator (3/4" NPT Female). Connect the respirator system or pneumatic tool airline hose to the Quick Disconnect Coupling on the Outlet Air Top Flange. Tighten all piping connections to prevent air leaks and/or air pressure loss.

California Proposition 65 WARNING

Cancer and Reproductive Harm - www.P65Warnings.ca.gov.



©2024 Bullard. All rights reserved.
Teflon is a registered trademark
of E.I. DuPont de Nemours Co.

60810012674C (0724)